



Achtung
Attention
Attention
Atención



Gebrauchsanleitung
Instructions for use
Mode d'emploi
Modo de empleo



Information
Information
Information
Información

Gebrauchsinformation / Information for use
Information d'emploi / Información de uso

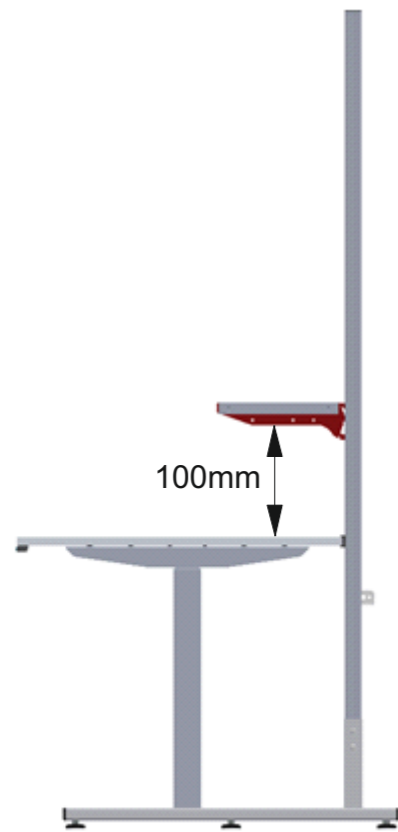

Der Mindestabstand von 100mm zwischen Tischplatte -in höchster Position- und Zubehörteilen (bspw. Blechablage) muss zu jeder Zeit sichergestellt sein. Sollte der Mindestabstand nicht eingehalten werden können, so muss der Hub begrenzt werden.

Nachzulesen in der Betriebsanleitung.

The minimum distance of 100mm between the table top - in the highest position - and the accessories (e.g. sheet metal shelf) must be ensured at all times. If the minimum distance cannot be maintained, the stroke must be limited.

Please refer to the operating instructions.

La distance minimale de 100 mm entre le plateau de table -dans la position la plus haute - et les accessoires (par exemple, l'étagère en tôle) doit être garantie à tout moment. Si la distance minimale ne peut pas être maintenue, l'élévation doit être limitée.

Pour plus d'informations, lisez le manuel d'instructions.

La distancia mínima de 100mm entre el tablero -en la posición más alta- y los accesorios (por ejemplo, la estantería de chapa) debe estar garantizada en todo momento. Si no se puede mantener la distancia mínima, la elevación debe ser limitado.

Para más información lea el manual de instrucciones.

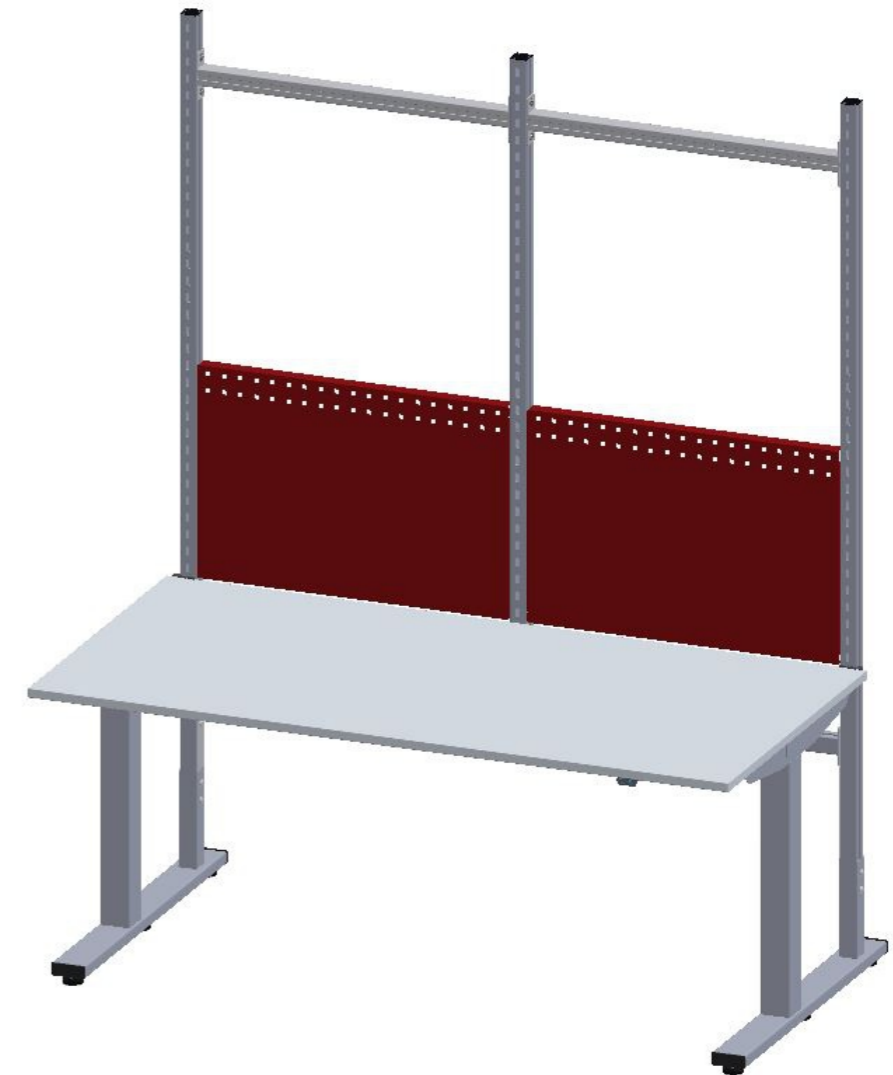

Montageanleitung / Gebrauchsanleitung
Mounting instructions / Instructions for use
Instructions de montage / Mode d'emploi
Instrucciones de montaje / Modo de empleo

08/21 93090643



SYSTEM FLEX LIGHT



Lieferumfang
Contents
Contenu
Contenido



Montageanleitung
Mounting instructions
Instructions de montage
Instrucciones de montaje

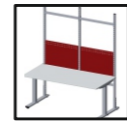

Gebrauchsanleitung
Instructions for use
Mode d'emploi
Modo de empleo



Achtung
Attention
Attention
Atención



Gebrauchsanleitung
Instructions for use
Mode d'emploi
Modo de empleo



Information
Information
Information
Información

73805200

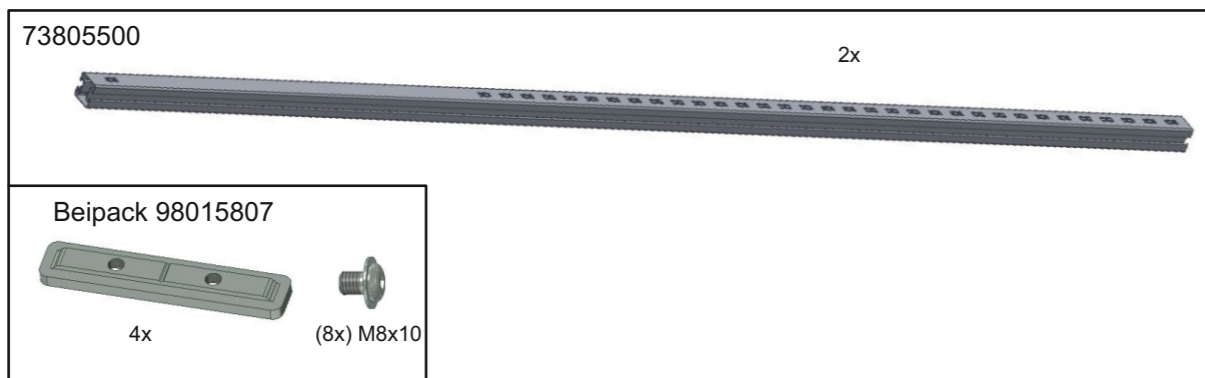
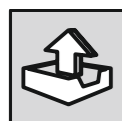
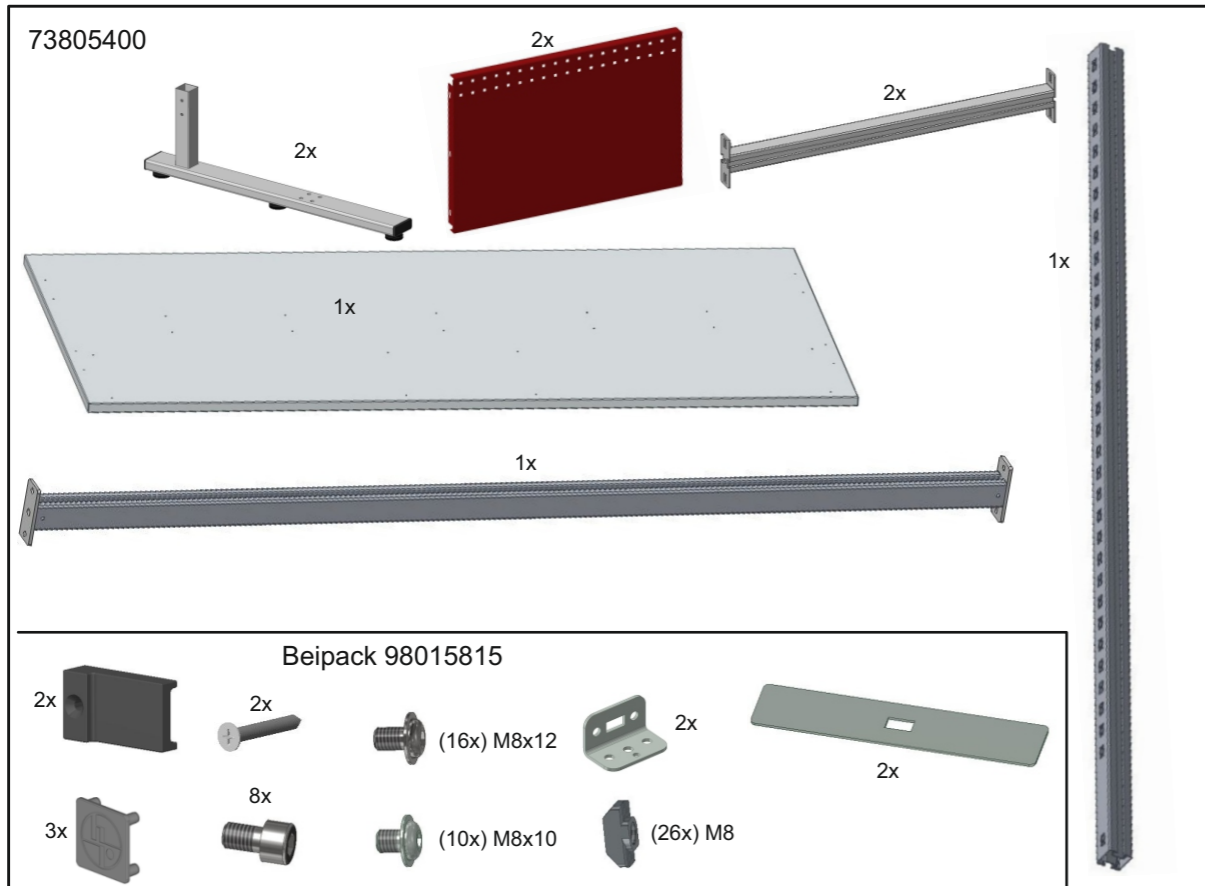
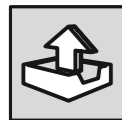
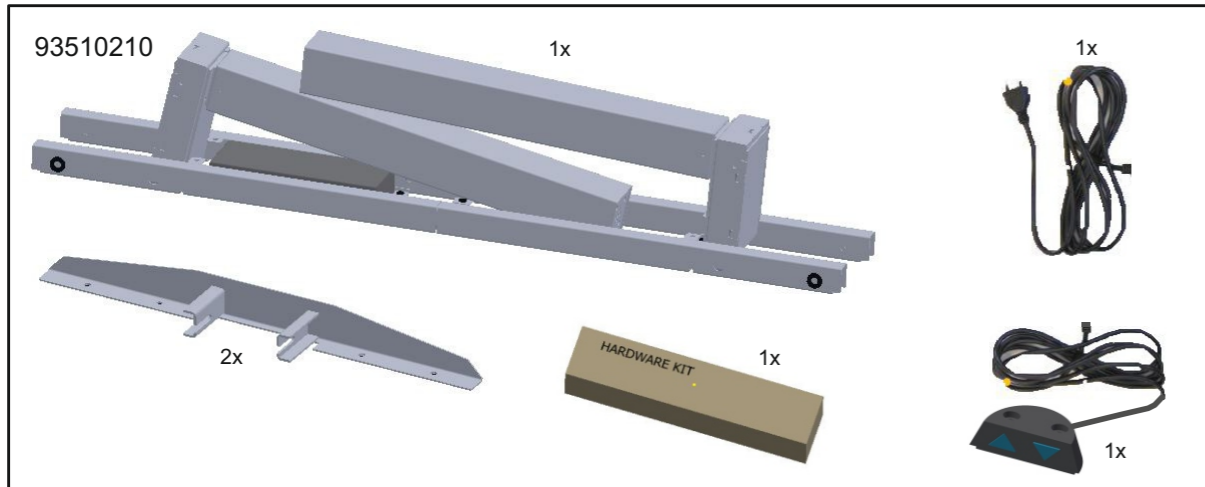
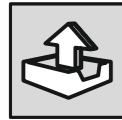

Gebrauchsinformation / Information for use
Information d'emploi / Información de uso

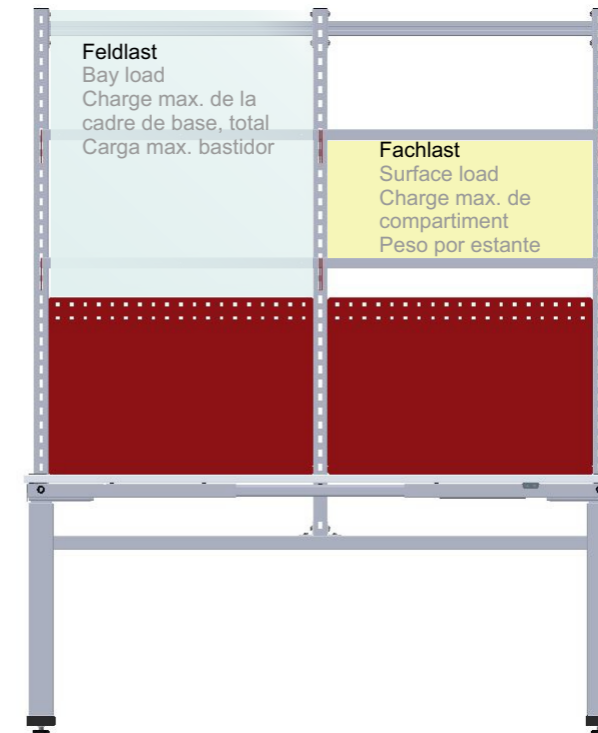

Große Punktlasten, sowie stark einseitige Belastungen sind zu vermeiden. Beim Beladen der Anbauten ist darauf zu achten, dass keine großen dynamischen Kräfte entstehen. (z.B. Kartons auf die Ablageböden werfen)
Bei den Ablagen ohne gesonderte Angaben zur max. Belastung gilt eine max. zulässige Fachlast von 25 kg.

Grundsätzlich gilt eine max. Feldlast von 75 kg und eine max. Flächenlast auf der Tischplatte von 100 kg.

Avoid large point loads and heavy one-sided loads. While loading the extensions, take care that no large dynamic forces are created (e.g. throwing boxes on shelves)
Shelves without separate information have a max. surface load of 25 kg.

In general, a max. bay load of 75 kg and a max. surface load on the table top of 100 kg applies.

Évitez les charges ponctuelles importantes et les lourdes charges unilatérales. Pendant le chargement des extensions, veuillez à ce qu'aucune force dynamique importante ne soit créée (par exemple en lançant des boîtes sur les étagères).
Les étagères sans information séparée ont un max. charge de surface de 25 kg.

Par Compartiment s'applique un max. charge de 75 kg et un charge de surface sur le dessus de table de 100 kg.

Grandes cargas puntuales y cargas unilaterales son de evitar. Se deben evitar las fuerzas dinámicas al cargar sobre los soportes superiores (por ejemplo evitar de echar/tirar paquetes sobre los estantes)

La carga máxima por estante sin ninguna otra indicación es de 25 kg.

Básicamente la capacidad de carga entre los largueros/extensions es de 75 kg y la máxima carga superficial sobre el tablero de la mesa es de 100 kg..



Montageanleitung
Mounting instructions
Instructions de montage
Instrucciones de montaje

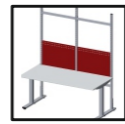

Gebrauchsanleitung
Instructions for use
Mode d'emploi
Modo de empleo



2 Personen
2 Persons
2 Personnes
2 Personas

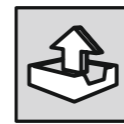

Lieferumfang
Contents
Contenu
Contenido



Montageanleitung
Mounting instructions
Instructions de montage
Instrucciones de montaje

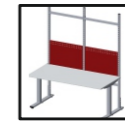

Gebrauchsanleitung
Instructions for use
Mode d'emploi
Modo de empleo

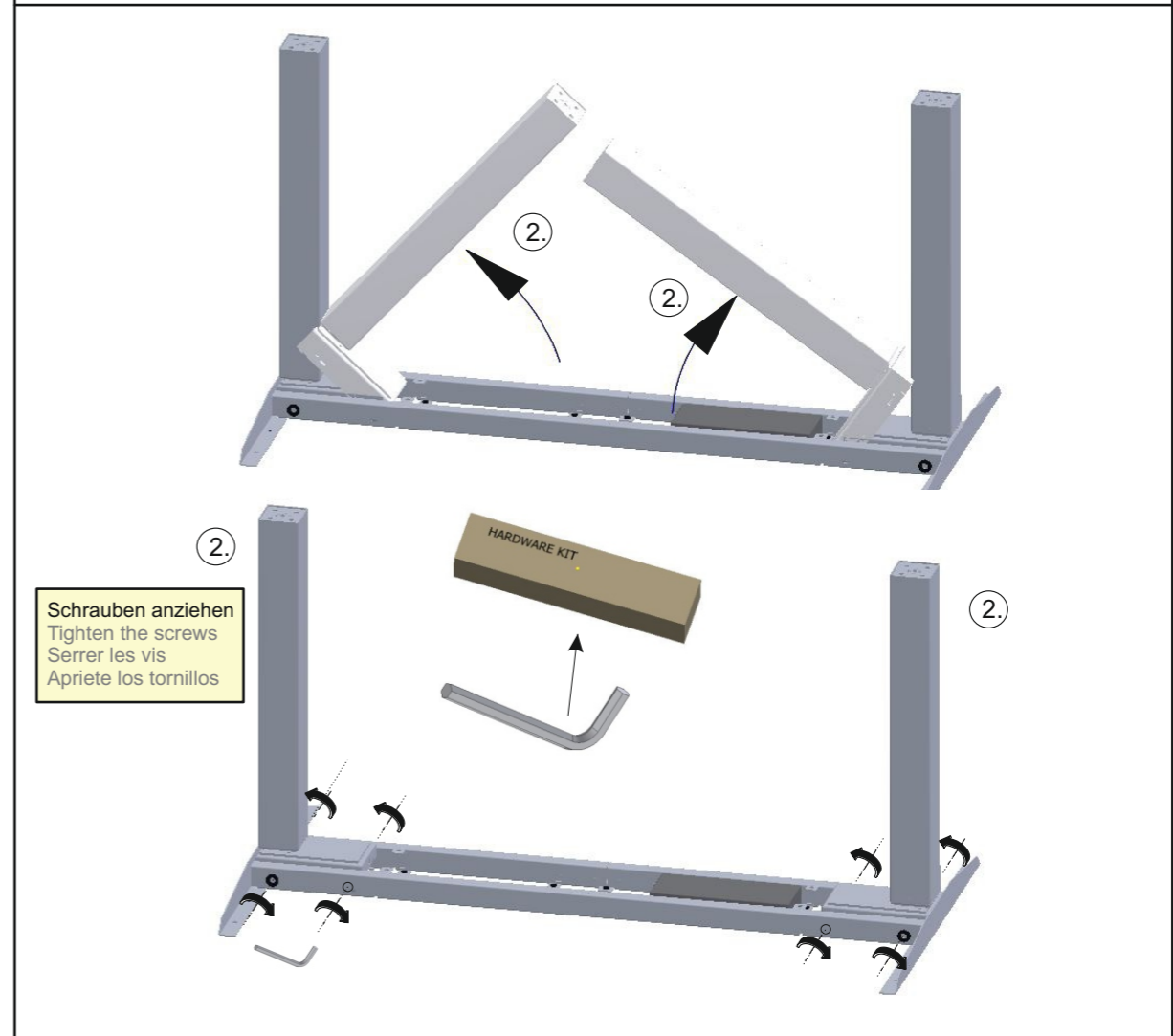
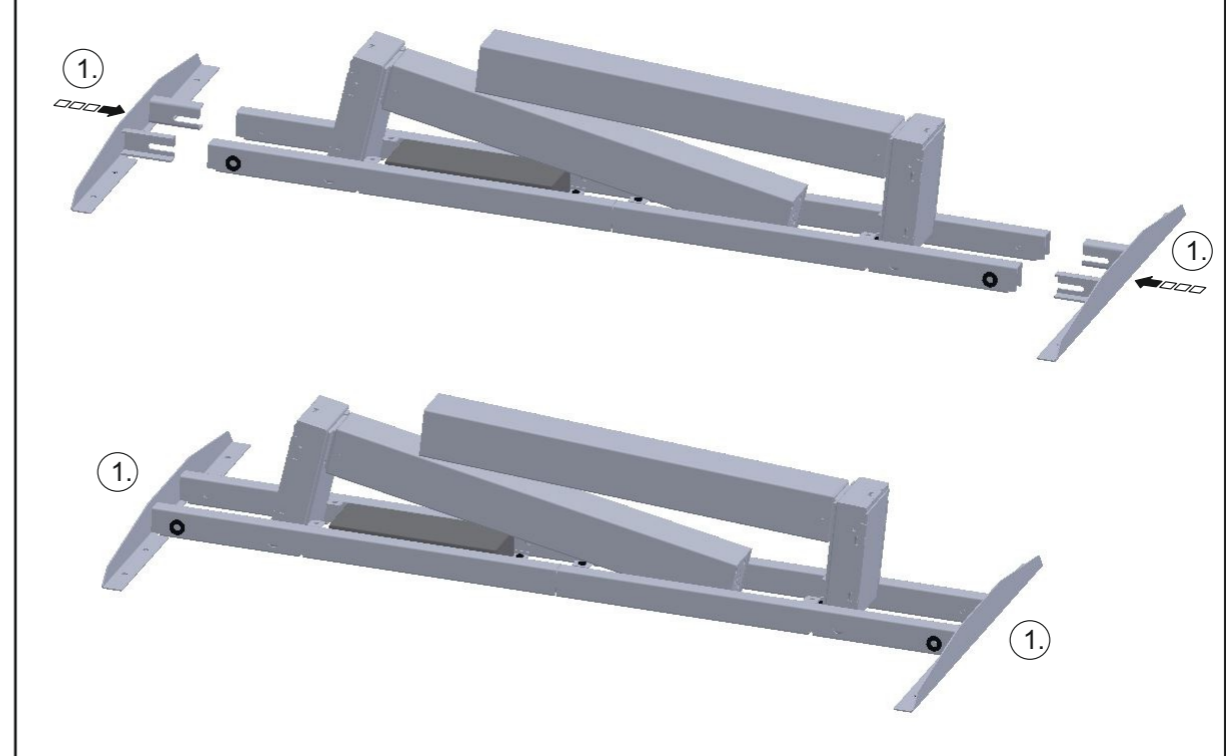
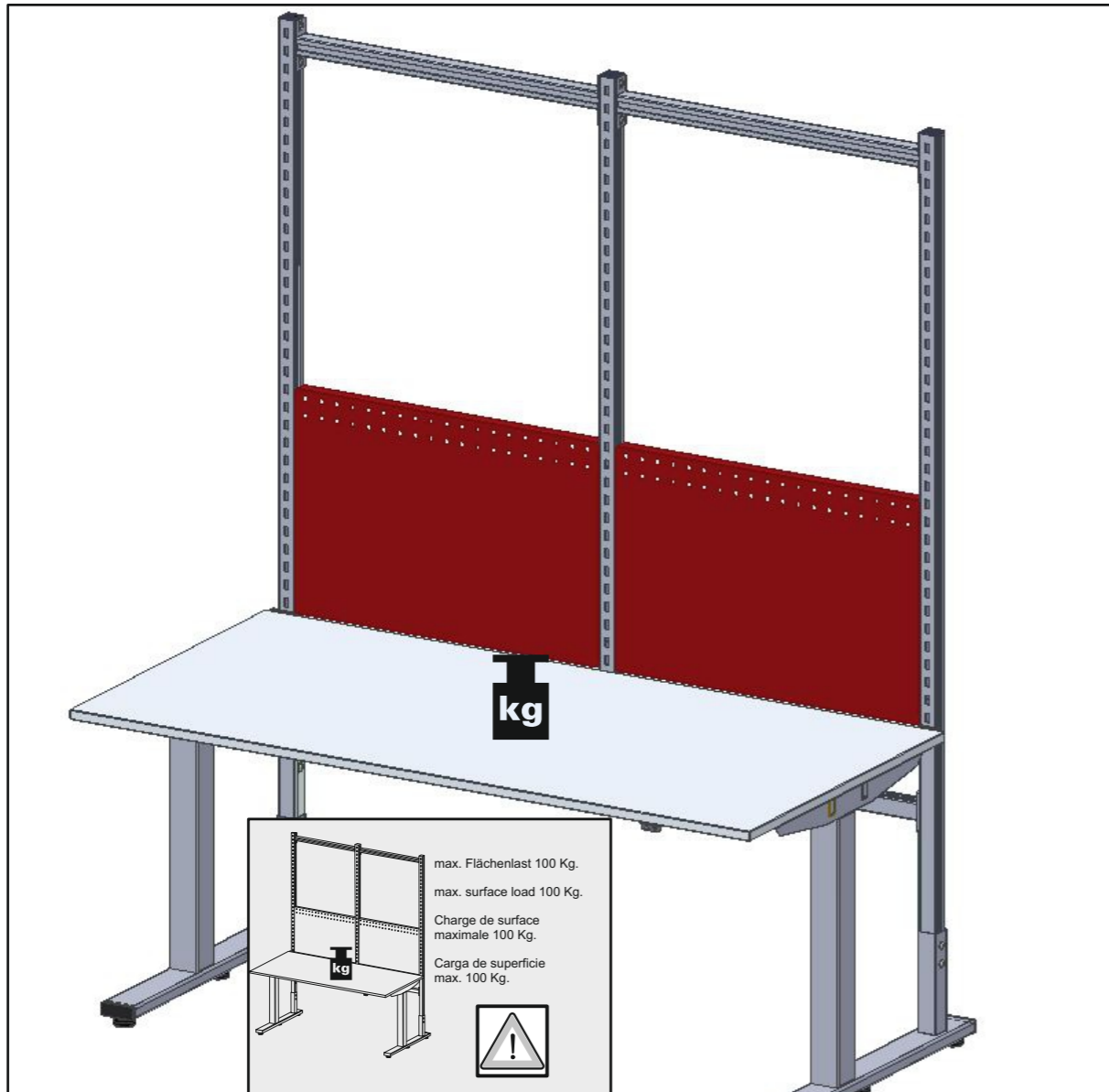
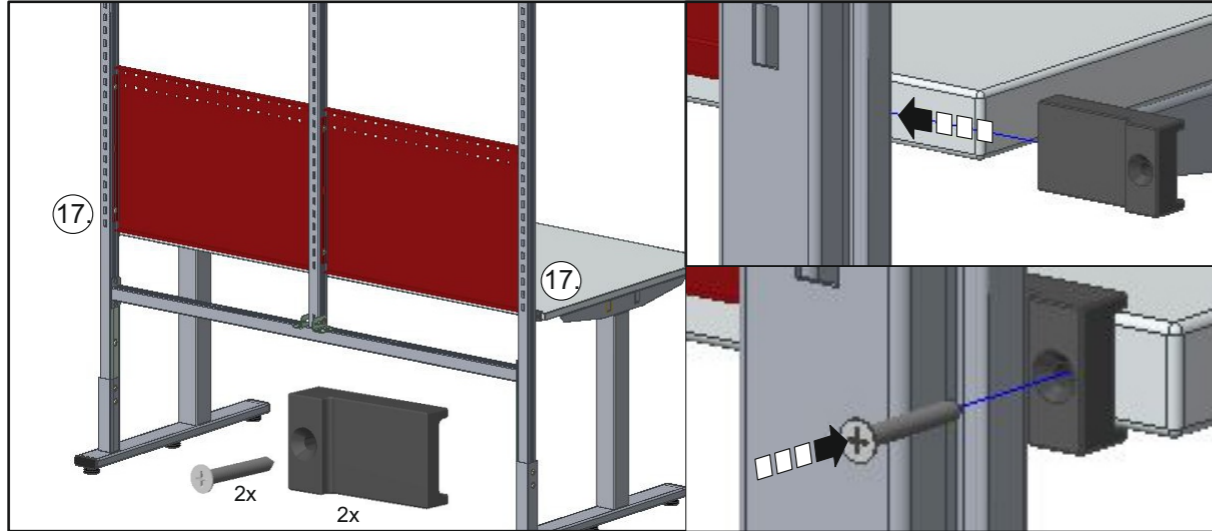



Montageanleitung
Mounting instructions
Instructions de montage
Instrucciones de montaje

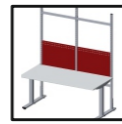

Gebrauchsanleitung
Instructions for use
Mode d'emploi
Modo de empleo



2 Personen
2 Persons
2 Personnes
2 Personas

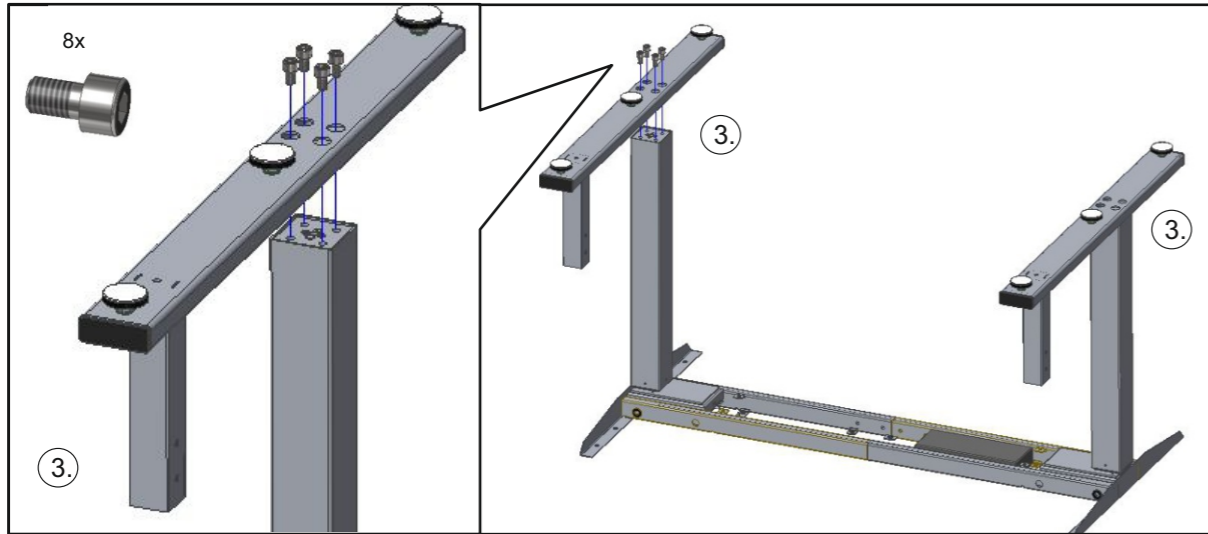

Montageanleitung
Mounting instructions
Instructions de montage
Instrucciones de montaje

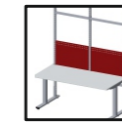

Gebrauchsanleitung
Instructions for use
Mode d'emploi
Modo de empleo



2 Personen
2 Persons
2 Personnes
2 Personas

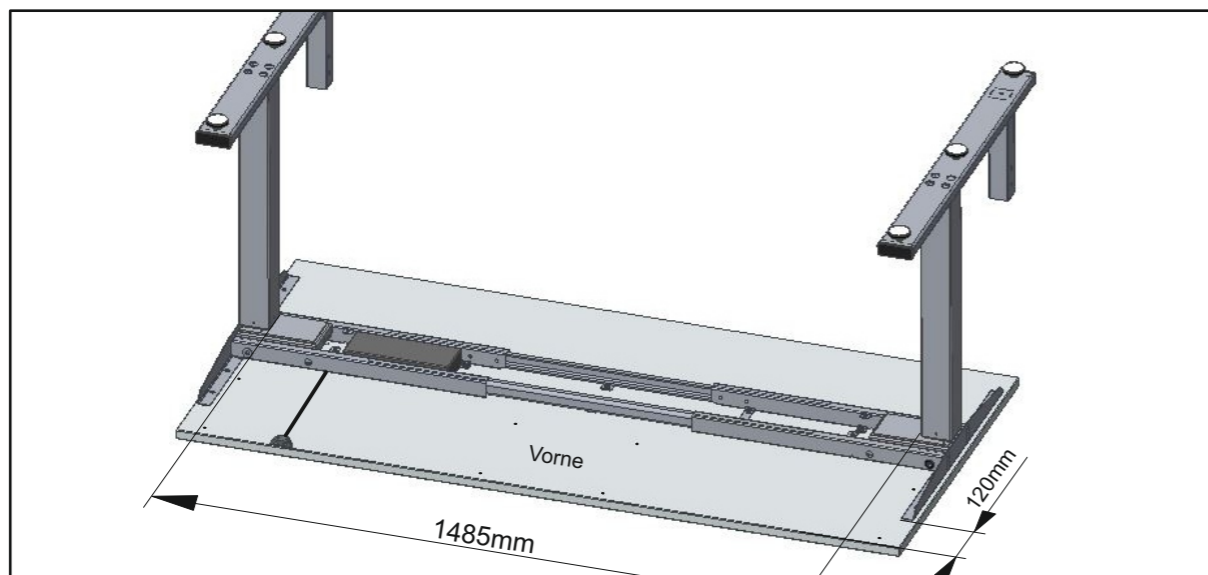
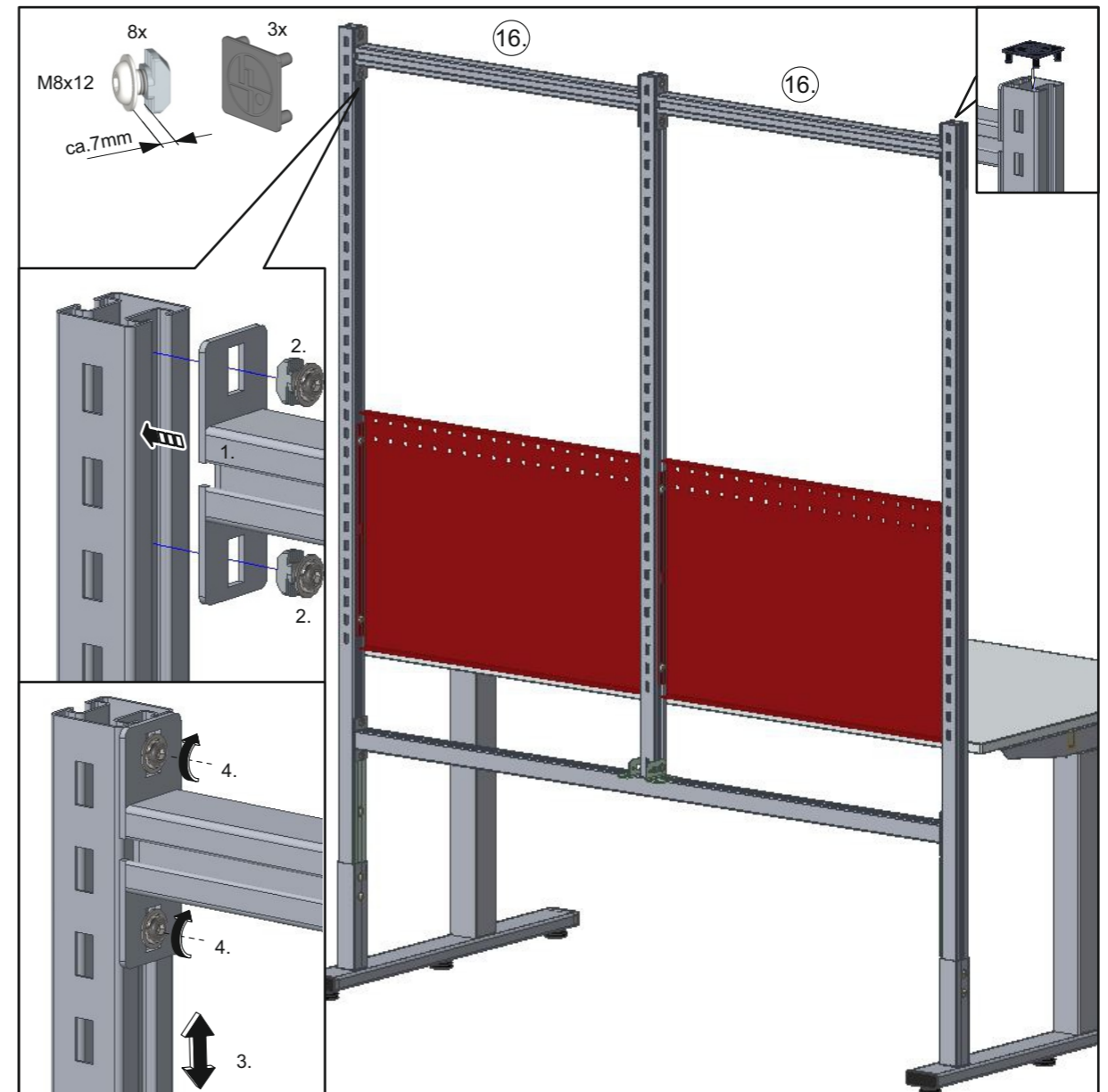
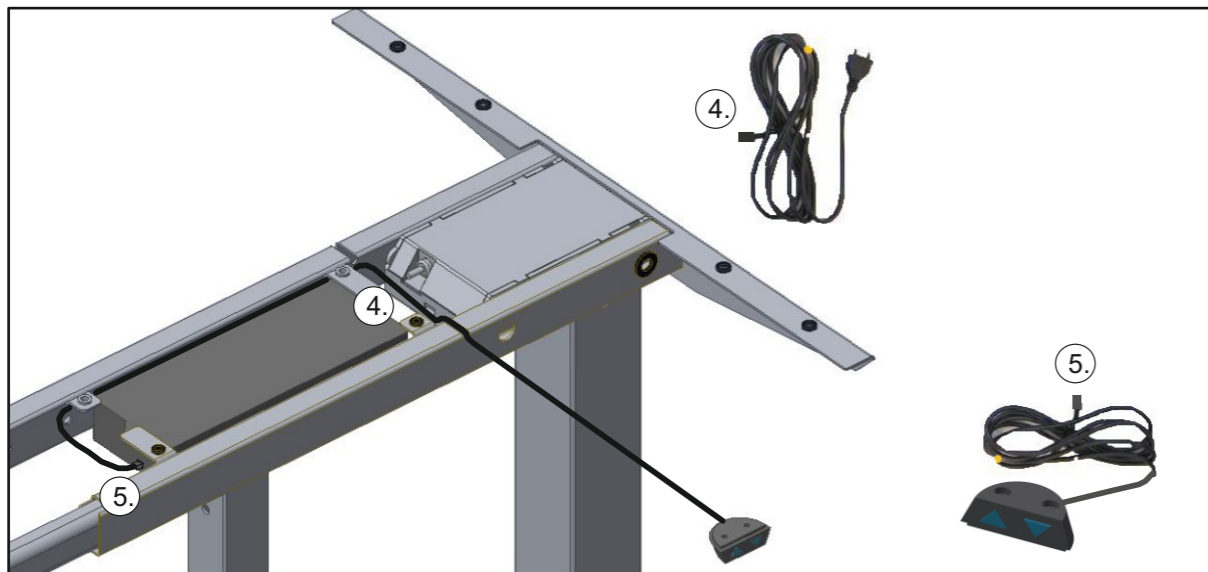
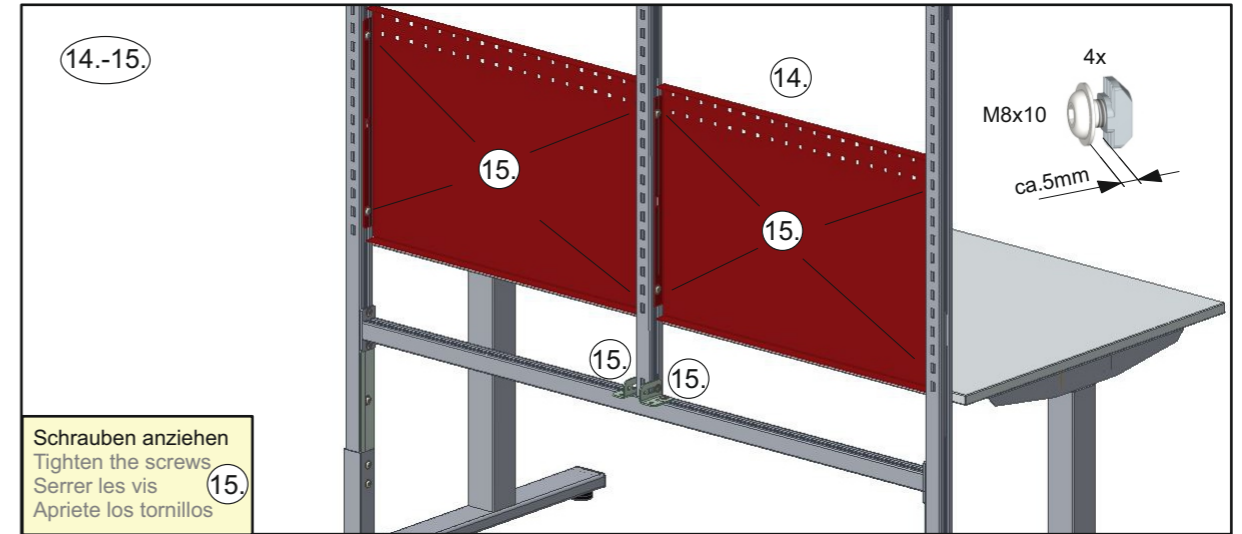



Montageanleitung
Mounting instructions
Instructions de montage
Instrucciones de montaje

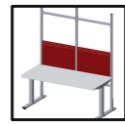

Gebrauchsanleitung
Instructions for use
Mode d'emploi
Modo de empleo



2 Personen
2 Persons
2 Personnes
2 Personas



Montageanleitung
Mounting instructions
Instructions de montage
Instrucciones de montaje

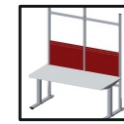

Gebrauchsanleitung
Instructions for use
Mode d'emploi
Modo de empleo



2 Personen
2 Persons
2 Personnes
2 Personas

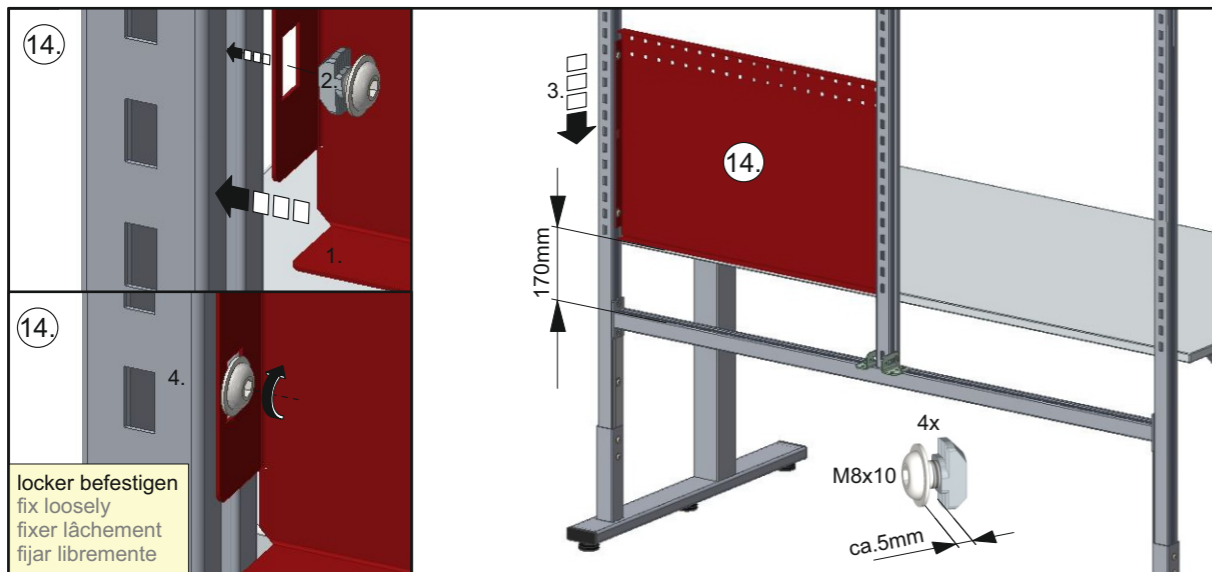
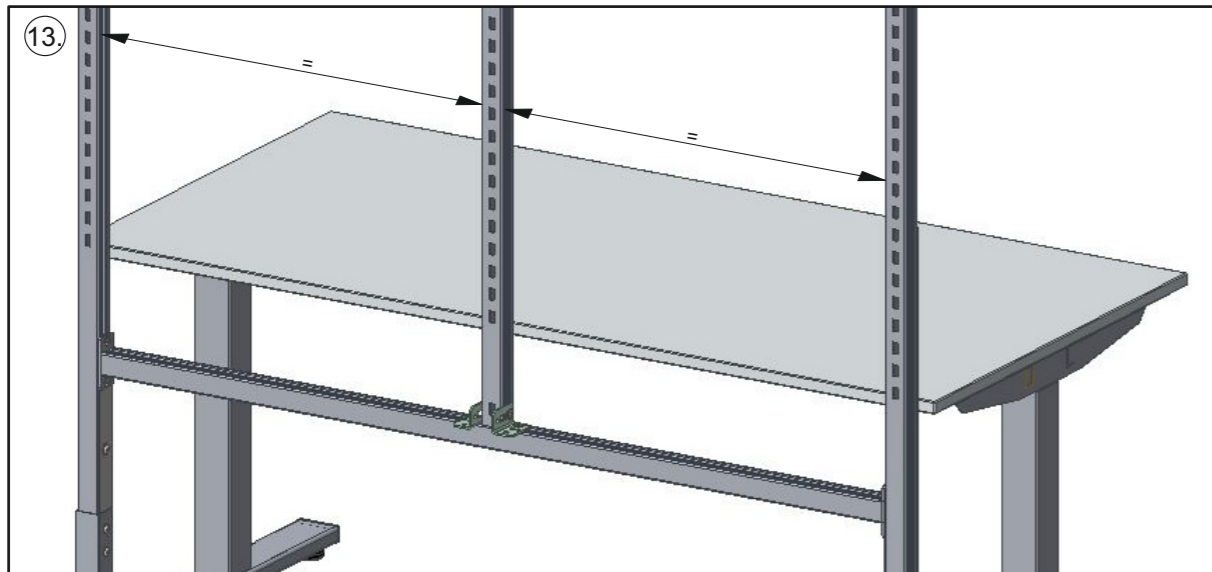
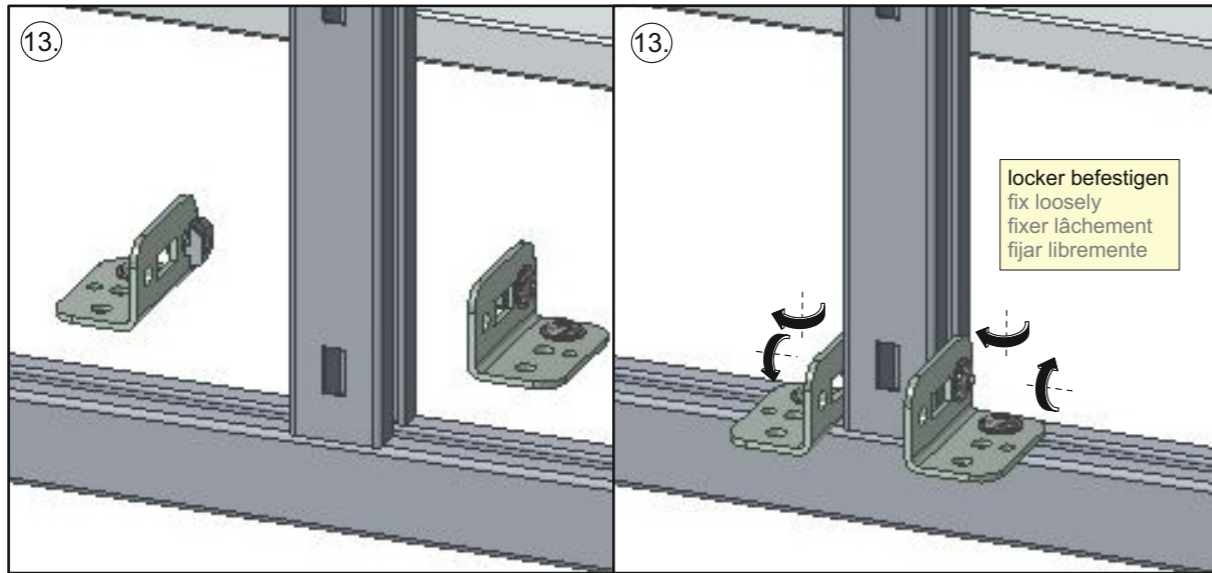

8.

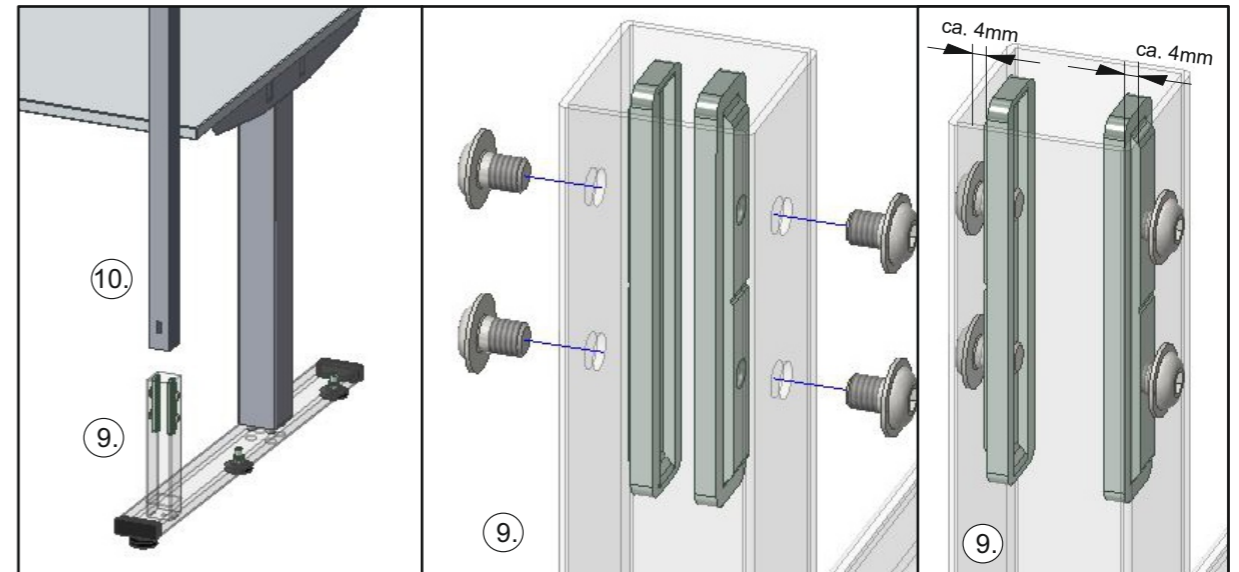
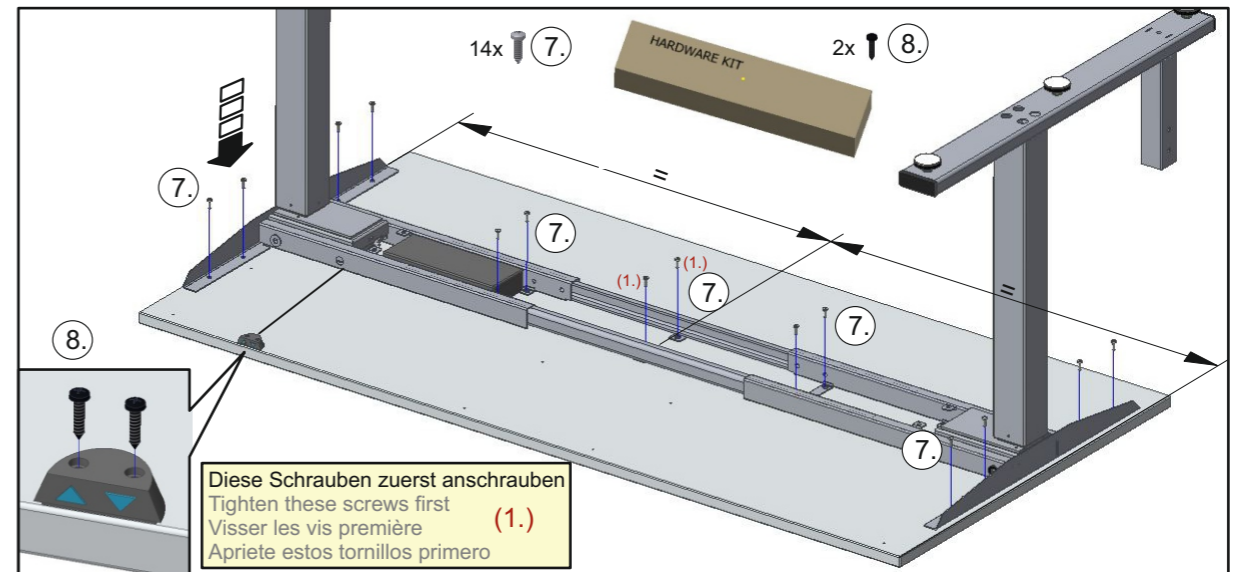
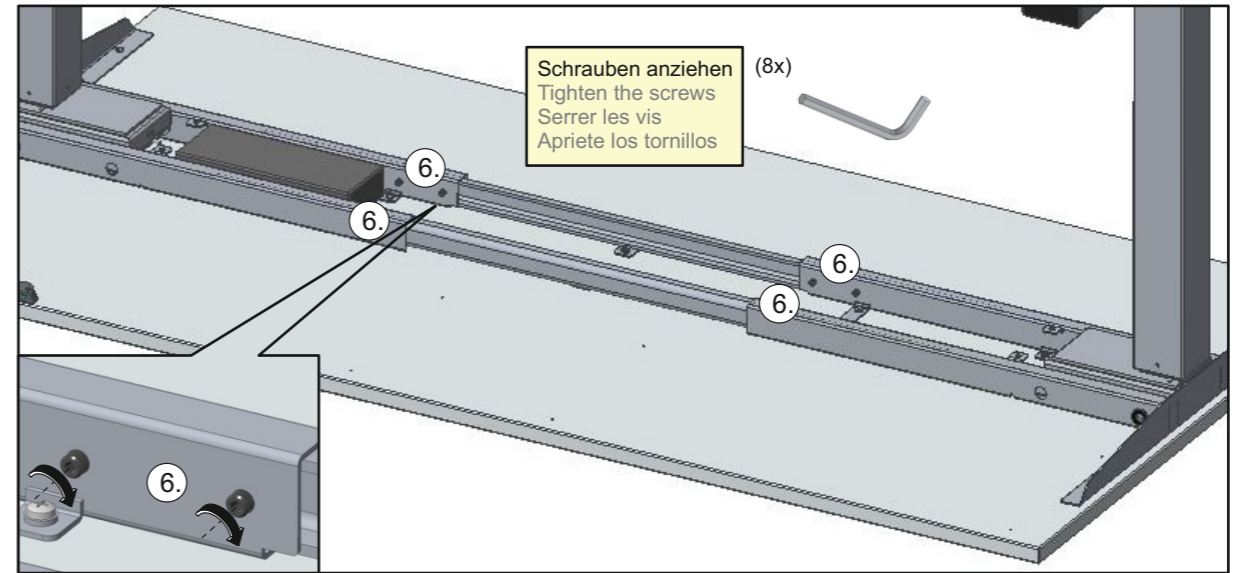

5.



Montageanleitung
Mounting instructions
Instructions de montage
Instrucciones de montaje

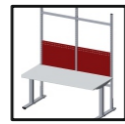

Gebrauchsanleitung
Instructions for use
Mode d'emploi
Modo de empleo



2 Personen
2 Persons
2 Persones
2 Personas

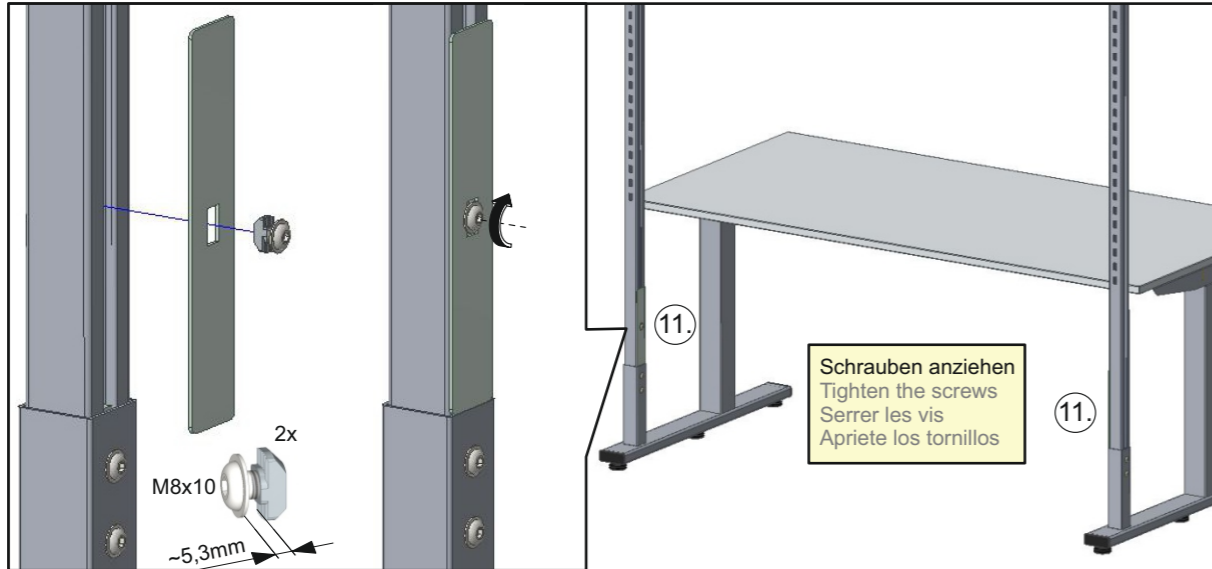
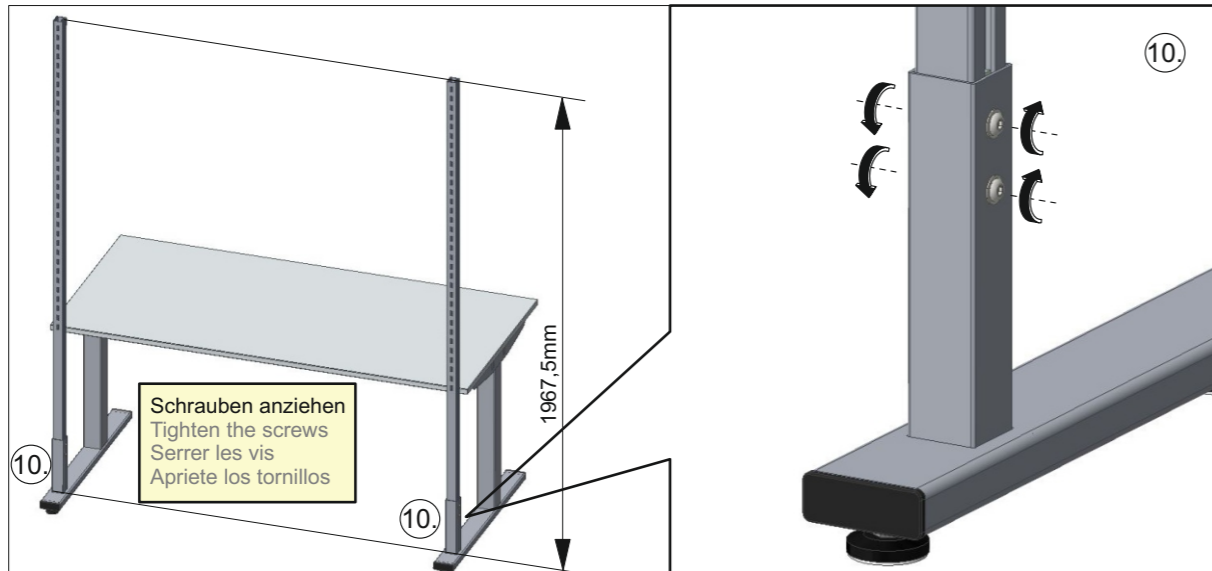
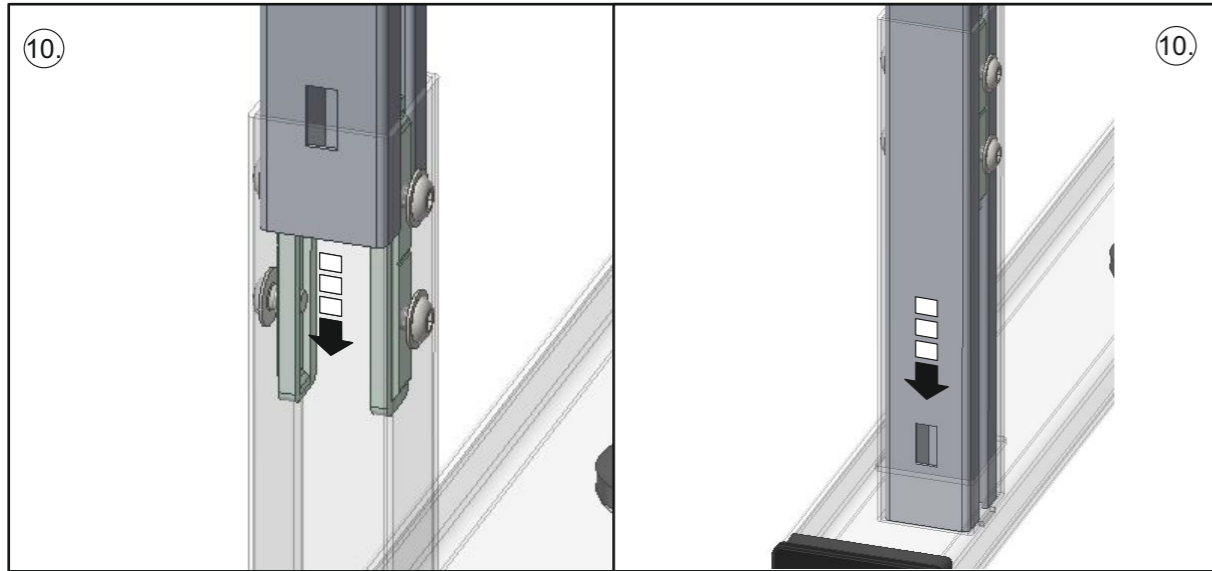

6.



Montageanleitung
Mounting instructions
Instructions de montage
Instrucciones de montaje

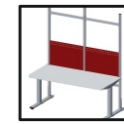

Gebrauchsanleitung
Instructions for use
Mode d'emploi
Modo de empleo



2 Personen
2 Persons
2 Persones
2 Personas

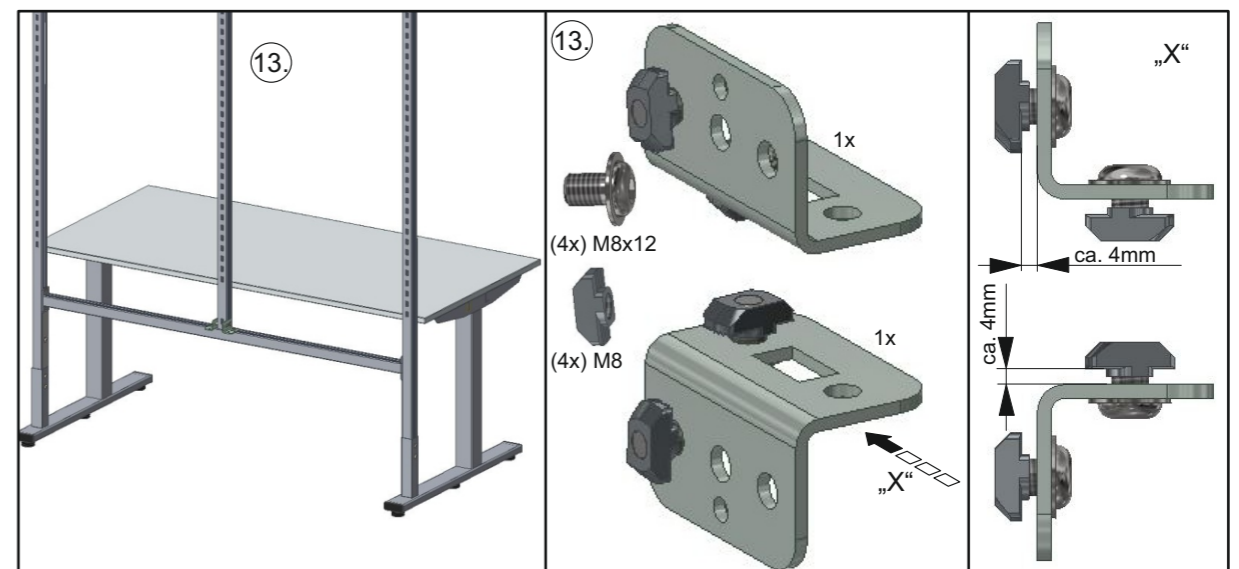
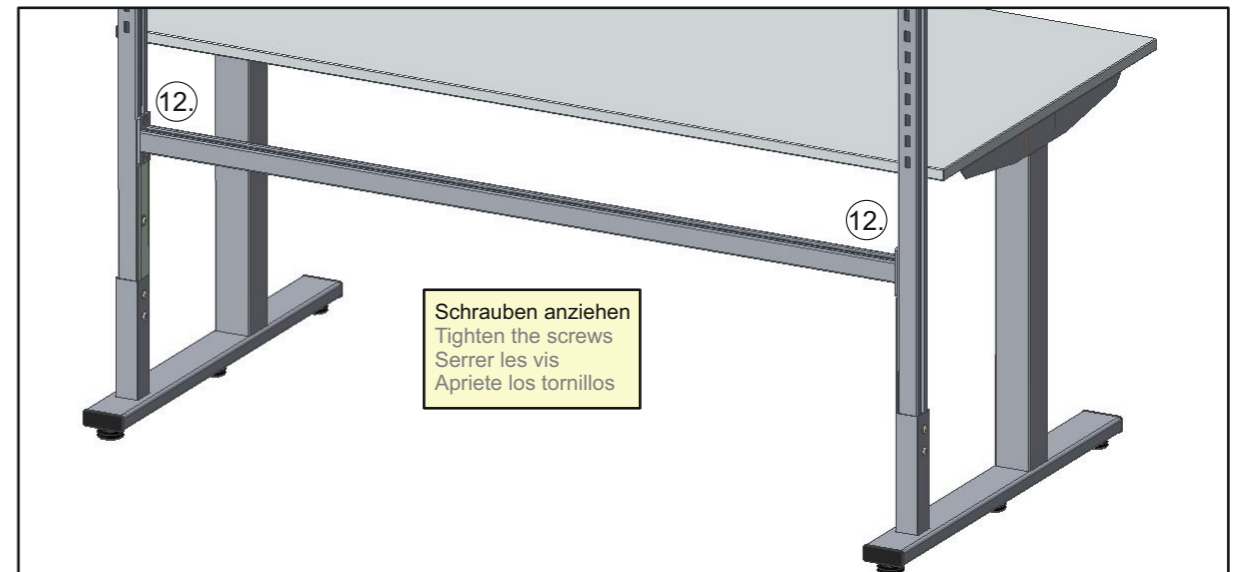
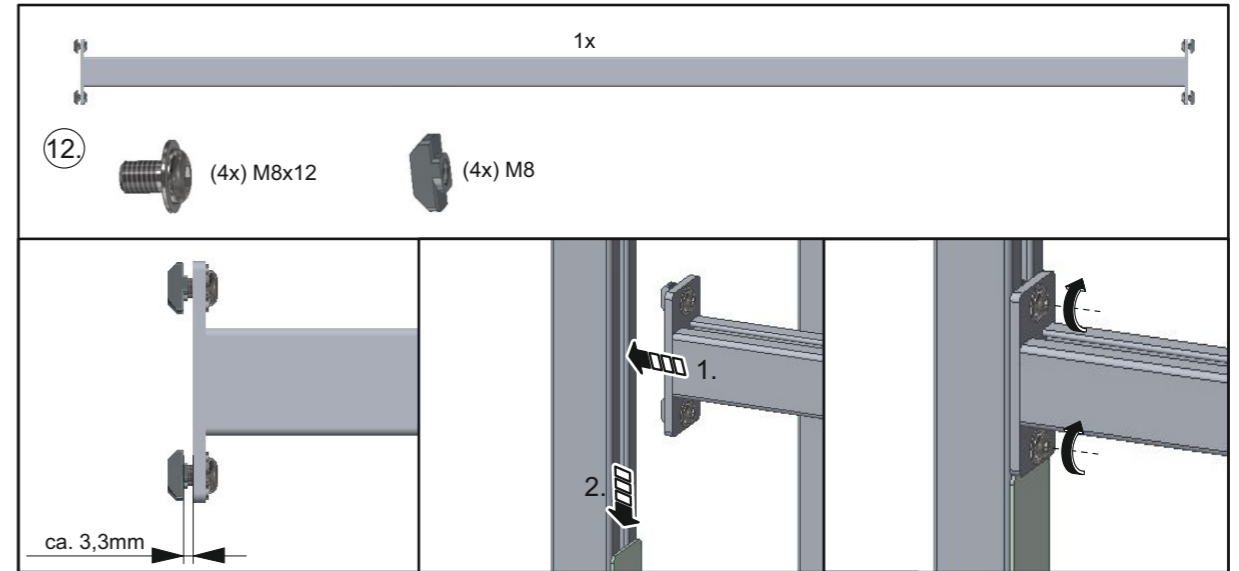

7.